

Resummation of large logarithms in $\gamma^*\pi^0 \rightarrow \gamma$

Feng Feng and Jian-Ping Ma

*Institute of Theoretical Physics, Academia Sinica,
Beijing 100080, China
E-mail: fengfeng@itp.ac.cn, majp@itp.ac.cn*

Qi Wang

*Department of Physics and Institute of Theoretical Physics,
Nanjing Normal University, Nanjing, Jiangsu 210097, P.R. China
E-mail: wangqinj@njnu.edu.cn*

ABSTRACT: In the collinear factorization of the form factor for the transition $\gamma^*\pi^0 \rightarrow \gamma$ the hard part contains double log terms as $\ln^2 x$ with x as the momentum fraction of partons from 0 to 1. A simple exponentiation for resummation leads to divergent results. We study the resummation of these $\ln^2 x$ terms. We show that the $\ln^2 x$ terms come partly from the light-cone wave function(LCWF) and partly from the form factor. We introduce a jet factor to factorize the $\ln^2 x$ term in the form factor. To handel the $\ln^2 x$ terms from the LCWF we introduce a nonstandard light-cone wave function(NLCWF) with the gauge links off the light-cone direction. An interesting relation between two wave function is found. With the introduced NLCWF and the jet factor we can re-factorize the form factor and obtain a new hard part which does not contain terms with $\ln^2 x$. Beside the renormalization scale μ the introduced NLCWF and jet factor have extra scales to characterize their x -behaviors. Using the evolutions of the extra scales and the relation we can do the resummation perturbatively in sense that the LCWF is the only nonpertubative object in the resumed formula. Our results with some models of LCWF show that there is a significant difference between numerical predictions with the resummation and that without the resummation, and the resumed predictions can describe the experimental data.

KEYWORDS: QCD, NLO Computations.

Contents

1. Introduction	1
2. Notations and the origin of $\ln^2 x$	3
3. Nonstandard light cone wave function	7
4. The jet factor and re-factorization	11
5. Resummation	13
6. Numerical results and comparison with experiment	16
7. Conclusion	16

1. Introduction

Predictions with perturbative QCD for an exclusive process can be made if it contains short-distance effects beside long-distance effects. In order to use the perturbative theory of QCD one needs to separate or factorize long distance and short-distance effects. Only the latter, which are characterized by a large energy scale denoted generically as Q , can be studied with perturbative QCD. It has been proposed long time ago that such a process can be studied by an expansion of the amplitude in $1/Q$, corresponding to an expansion of QCD operators in twist [1, 2]. The leading term can be factorized as a convolution of a hard part and light-cone wave functions of hadrons. The light-cone wave functions are defined with QCD operators, and the hard part describes hard scattering of partons at short distances. The hard part can be safely calculated with perturbative QCD in the sense that it does not contain any infrared(I.R.)- and collinear divergences. This is the so-called collinear factorization. In this factorization the transverse momenta of partons in parent hadrons are also expanded in the hard scattering part and they are neglected at leading twist.

Although the hard part does not contain any of I.R.- and collinear singularities, as an perturbative expansion it contains large logarithms at higher orders of α_s . These large logarithms are dangerous and can spoil the expansion in the sense that the expansion does not converge. A resummation of large logarithms is often needed to have a reliable prediction. In this paper we study the resummation in the process $\gamma^* \pi^0 \rightarrow \gamma$. Theoretically, the process has been studied with QCD factorization extensively [3–9]. Experimentally it has

been studied too [10]. With the collinear factorization the form factor $F(Q)$ characterizing the process can be written as

$$F(Q) \sim \phi \otimes H \left\{ 1 + \frac{\Lambda^2}{Q^2} \right\}. \quad (1.1)$$

In the above ϕ is the light-cone wave function(LCWF) of π^0 , H is the hard part, and Q^2 is the virtuality of the virtual photon. The correction to the factorized form is power-suppressed and is proportional to Λ^2/Q^2 . Λ is any possible soft scale characterizing non-perturbative scale, like Λ_{QCD} , the mass of π etc.. This scale is about several hundreds MeV. In [8] the hard part in the collinear factorization has been calculated at one-loop, its two-loop result can be found in [9]. At one-loop level one finds that H contains a double log $\alpha_s \ln^2 x$, where x is the momentum fraction carried by a parton with $0 \leq x \leq 1$. It is expected that at n -loop level, it will contain $\alpha_s^n \ln^{2n} x$. Those double log terms will become divergent when x is approaching to zero and can spoil the perturbative expansion of H . Although the double log terms are integrable with x in the convolution and give finite contributions, but they are significant corrections. The purpose of our study is to resum those double log terms.

In order to resum those double log terms we need to understand their origin. Given the factorized form in the above, H will receive contributions from the form factor and the LCWF. When we use a finite quark mass to regularize the collinear singularities, we can show that the log terms come from the form factor and the LCWF. These terms can be re-factorized by introducing a jet factor and a nonstandard light-cone wave function(NLCWF), where the jet factor contains the double log from the form factor and the NLCWF does not have double log. In introducing these two objects in the re-factorization, two extra scales, which will be explained later, are introduced. One of them is related to the $\ln^2 x$ term from LCWF, while another is related to $\ln^2 x$ in the form factor. The new hard part \tilde{H} from the re-factorization will not contain $\ln^2 x$. With evolution equations of these scales we are able to resum the $\ln^2 x$ terms. Our approach is similar to the threshold resummation in inclusive processes studied in [11]. There exists an interesting relation between the two wave functions. In our approach, after the resummation of $\ln^2 x$, only the LCWF appears in the form factor as a nonperturbative object, other quantities can be calculated with perturbative QCD. With the knowledge of the LCWF we are able to give numerical results and to make a comparison with experiment.

It should be noted that it is possible to resum the large log terms in exclusive processes by taking transverse momenta of partons into account [12, 13]. By introducing transverse-momentum-dependent(TMD) light-cone wave-functions one can make TMD or k_t factorization in terms of the TMD light-cone wave functions. However, the consistence of the factorization needs to be carefully checked beyond tree-level. Recently, this has been studied in a series of papers [14, 15], where a consistent definition of TMD light-cone wave functions is proposed and the TMD factorization is examined beyond tree-level for some simple cases. However, unlike LCWF's there is little knowledge about TMD light-cone wave functions. Therefore, it may be difficult to give detailed predictions and to compare with experiment.

Our paper is organized as the following: In section 2 we introduce our notations and explain the origin of $\ln^2 x$. In section 3 we introduce NLCWF and present a one-loop study of the NLCWF. We also show that there is a perturbative relation between LCWF and NLCWF. In section 4 we introduce our jet factor and derive the factorization formula with the jet factor and NLCWF. In section 5 we give our resummation formula. We present our numerical results in section 6, where a comparison with experiment is also given. section 7 is our conclusion.

2. Notations and the origin of $\ln^2 x$

We consider the process:

$$\pi^0 + \gamma^* \rightarrow \gamma \tag{2.1}$$

where π^0 carries the momentum P and the real photon momentum p . We use the light-cone coordinate system, in which a vector a^μ is expressed as $a^\mu = (a^+, a^-, \vec{a}_\perp) = ((a^0 + a^3)/\sqrt{2}, (a^0 - a^3)/\sqrt{2}, a^1, a^2)$ and $a_\perp^2 = (a^1)^2 + (a^2)^2$. We take a frame in which the momentum P and p are:

$$P^\mu = (P^+, P^-, 0, 0), \quad p^\mu = (0, p^-, 0, 0). \tag{2.2}$$

We will consider the case that the virtual photon has the large negative virtuality $q^2 = (P - p)^2 = -2P^+p^- = -Q^2$. The process can be described by matrix element $\langle \gamma(p, \epsilon^*) | J_{e.m.}^\mu | \pi^0(P) \rangle$, which is parameterized with the form factor $F(Q^2)$:

$$\langle \gamma(p, \epsilon^*) | J_{e.m.}^\mu | \pi^0(P) \rangle = ie^2 \epsilon^{\mu\nu\rho\sigma} \epsilon_\nu^* P_\rho p_\sigma F(Q^2). \tag{2.3}$$

e is the charge of proton, i.e., $\alpha = e^2/(4\pi)$.

In the collinear factorization the form factor can be factorized as

$$F(Q^2) = \frac{Q_u^2 - Q_d^2}{\sqrt{2}} \frac{1}{Q^2} \int_0^1 dx \phi(x, \mu) H(x, Q, \mu) \left[1 + \mathcal{O}\left(\frac{\Lambda^2}{Q^2}\right) \right], \tag{2.4}$$

where ϕ is the LCWF of π^0 , H is a perturbative function or a hard part. Q_u and Q_d are the electric charge fraction of u and d quark in unit of e , respectively. ϕ is defined with QCD operators:

$$\phi(x, \mu) = \int \frac{dz^-}{2\pi} e^{ik^+z^-} \langle 0 | \bar{q}(0) L_n^\dagger(\infty, 0) \gamma^+ \gamma_5 L_n(\infty, z^- n) q(z^- n) | \pi^0(P) \rangle, \tag{2.5}$$

where the gauge link is defined along the light-cone direction $n^\mu = (0, 1, 0, 0)$ as:

$$L_n(\infty, z) = P \exp \left(-ig_s \int_0^\infty d\lambda n \cdot G(\lambda n + z) \right). \tag{2.6}$$

To find the hard part H , we replace the hadronic state with the partonic state:

$$\begin{aligned} |\pi^0(P)\rangle &\rightarrow |q(k_q), \bar{q}(k_{\bar{q}})\rangle, & k_q^\mu &= (k_q^+, k_q^-, 0, 0), & k_{\bar{q}}^\mu &= (k_{\bar{q}}^+, k_{\bar{q}}^-, 0, 0) \\ k_q^2 &= k_{\bar{q}}^2 = m^2, & k_q^+ &= x_0 P^+, & k_{\bar{q}}^+ &= (1 - x_0) P^+ = \bar{x}_0 P^+, \end{aligned} \tag{2.7}$$

where we use a small but finite quark mass m to regularize collinear singularities. The form factor calculated with the partonic state will in general contain collinear singularities. The LCWF calculated with the partonic state will also have collinear singularities. If the collinear factorization holds, the singularities of the form factor and the LCWF will be the same so that the hard part H will not contain any collinear- and I.R. singularities. Here we examine this explicitly and show the origin of $\ln^2 x$.

With the partonic state, the LCWF at tree level reads:

$$\phi^{(0)}(x, \mu) = \delta(x - x_0)\phi_0, \quad \phi_0 = \bar{v}(k_{\bar{q}})\gamma^+\gamma_5 u(k_q)/P^+. \quad (2.8)$$

At the leading order, the form factor receives contributions from diagrams in figure 1. It is straightforward to obtain the tree-level result from figure 1:

$$F(Q^2)|_{1a} = \phi_0 \frac{1}{3\sqrt{2}Q^2 x_0}, \quad F(Q^2)|_{1b} = \phi_0 \frac{1}{3\sqrt{2}Q^2(1-x_0)} = \phi_0 \frac{1}{3\sqrt{2}Q^2 \bar{x}_0}. \quad (2.9)$$

We will always use the notation $\bar{u} = 1 - u$. Combining it with the tree-level result of the LCWF, we can obtain a factorized form for the form factor at tree-level:

$$F(Q^2) = \frac{1}{3\sqrt{2}Q^2} \int dx \phi(x, \mu) \left[\frac{1}{x} + \frac{1}{\bar{x}} \right], \quad H^{(0)}(x, Q, \mu) = \frac{1}{x} + \frac{1}{\bar{x}}. \quad (2.10)$$

At one-loop level, there are 12 Feynman diagrams, 6 of them are given in figure 2. The other 6 diagrams are obtained from those in figure 2 by reversing the direction of the quark line, i.e., through charge conjugation. The diagrams in figure 2 represent the correction to figure1a, and the other 6 diagrams for the correction to figure 1b. Two corrections are related each other by charge conjugation. Hence we will need to study how the contributions from figure 2 can be factorized.

The contributions except that of figure 2a can be calculated in a straightforward way. We give gluons a small mass λ to regularize I.R. singularities. The results are:

$$\begin{aligned} F(Q^2)|_{2e} &= F(Q^2)|_{2f} = F(Q^2)|_{1a} \cdot \frac{\alpha_s}{6\pi} \left[-\ln \frac{\mu^2}{m^2} - 2 \ln \frac{\lambda^2}{m^2} - 4 \right], \\ F(Q^2)|_{2d} &= F(Q^2)|_{1a} \cdot \frac{-\alpha_s}{3\pi} \left[\ln \frac{\mu^2}{Q^2} - \ln x_0 + 1 \right], \\ F(Q^2)|_{2b} &= F(Q^2)|_{1a} \cdot \frac{2\alpha_s}{3\pi} \left[\frac{1}{2} \ln \frac{\mu^2}{Q^2} + \ln \frac{Q^2}{m^2} + \frac{1}{2} \ln x_0 \right], \\ F(Q^2)|_{2c} &= F(Q^2)|_{1a} \cdot \frac{2\alpha_s}{3\pi} \left\{ \frac{1}{\bar{x}_0} \left[-\frac{1}{2} \ln^2 x_0 + 2 \ln \bar{x}_0 \ln x_0 + \ln \frac{Q^2}{m^2} \ln x_0 - \frac{\pi^2}{3} + 2\text{Li}_2(x_0) \right] \right. \\ &\quad \left. + \frac{1}{2} \ln \frac{\mu^2}{Q^2} - \ln \frac{m^2}{Q^2} - \frac{2+x_0}{2\bar{x}_0} \ln x_0 \right\}. \end{aligned} \quad (2.11)$$

These results can also be found in [14]. From the above, the $\ln^2 x$ term comes only from figure 2c. The origin of this $\ln^2 x$ is the following: The quark propagator connecting the vertex which emits the real photon carries the momentum $(xP^+, -p^-, 0, 0) + \mathcal{O}(m^2)$. If x becomes small and goes to zero, the momentum becomes light-cone-like. If the momentum

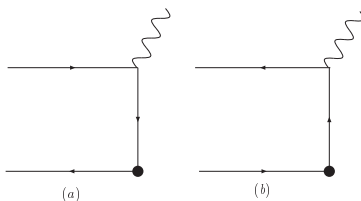

Figure 1: Feynman diagrams of tree-level contributions to the partonic scattering. The black dot denotes the insertion of the electric current operator corresponding to the virtual photon.

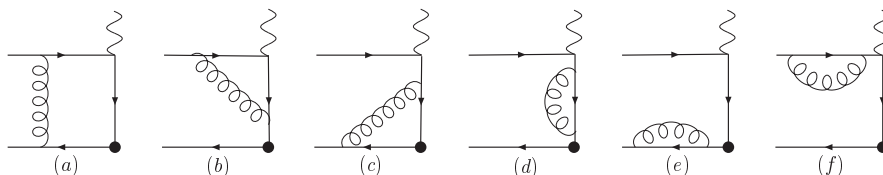

Figure 2: Feynman diagrams of the one-loop corrections to figure 1a.

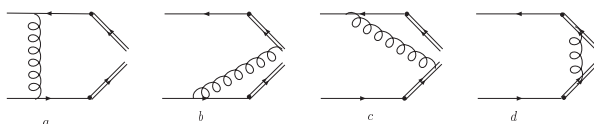

Figure 3: Feynman diagrams of the one-loop corrections to LCWF. The double line stands for the gauge link.

of the exchanged gluon is in the region collinear to the $--$ direction, after the loop integration a collinear singularity regularized by the small x appears. However, the region also overlaps with the infrared region where all components of the momentum are at order of xQ . This region generates an I.R. singularity which is also regularized by the small x . Therefore, the contribution from figure 2c contains $\ln^2 x$, one comes from the collinear singularity and another from the infrared singularity. We will show later that the dominant contribution containing $\ln^2 x$ in these regions can be obtained by the eikonal approximation and can be factorized by using the method suggested in [16]. It has also been suggested by using a jet factor to absorb the $\ln^2 x$ term [17]. With a similar analysis one can show that the contribution from figure 2b does not contain the collinear singularity related to the $--$ direction when x becomes small. It contains only the infrared singularity regularized by x . Hence it does not contain $\ln^2 x$ as shown explicitly in eq. (2.11).

The one-loop correction of the LCWF is given by some of diagrams in figure 3 and figure 4. The diagrams with the gluon-exchange between gauge links give no contribution here because $n^2 = 0$. The one-loop part of LCWF is the sum:

$$\phi^{(1)}(x, \mu) = \phi(x, \mu)|_{3a} + \phi(x, \mu)|_{3b} + \phi(x, \mu)|_{3c} + \phi(x, \mu)|_{4a} + \phi(x, \mu)|_{4c} + \phi(x, \mu)|_{4d} + \phi(x, \mu)|_{4f}, \tag{2.12}$$

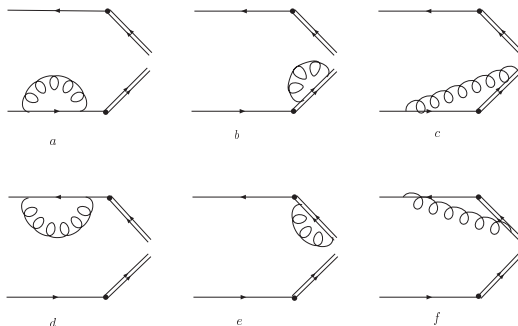

Figure 4: Feynman diagrams of the one-loop corrections to LCWF. The double line stands for the gauge link.

The one-loop results can be found in [14]. They are:

$$\begin{aligned}
 \phi(x, \mu)|_{4a} &= \phi(x, \mu)|_{4d} = \frac{\alpha_s}{6\pi} \left[-\ln \frac{\mu^2}{m_q^2} + 2 \ln \frac{m_q^2}{\lambda^2} - 4 \right] \phi_0, \\
 \phi(x, \mu)|_{3c} + \phi(x, \mu)|_{4f} &= -\frac{2\alpha_s}{3\pi} \phi_0 \theta(x - x_0) \left[\frac{\bar{x}}{\bar{x}_0(x - x_0)} \ln \frac{m_q^2(x - x_0)^2}{\mu^2 \bar{x}_0^2} \right]_+, \\
 \phi(x, \mu)|_{3b} + \phi(x, \mu)|_{4c} &= \frac{2\alpha_s}{3\pi} \phi_0 \theta(x_0 - x) \left[\frac{x}{x_0(x - x_0)} \ln \frac{m_q^2(x - x_0)^2}{\mu^2 x_0^2} \right]_+. \quad (2.13)
 \end{aligned}$$

With the above results the one-loop contribution of H can be determined as:

$$H^{(1)}(x_0, Q, \mu) = F^{(1)}(Q) - \int_0^1 dx \phi^{(1)}(x, \mu) H^{(0)}(x, Q, \mu). \quad (2.14)$$

It is obvious that the contributions from figure 2e and figure 2f are already contained in the contribution of figure 4a and figure 4d of the LCWF, respectively. The contribution from figure 3a has a complicated expression. However, for the purpose of the factorization, we only need the contribution at the leading power of Q^2 . We have the result for the combination:

$$Q^2 F(Q^2)|_{2a} - \phi|_{3a} \otimes H_{1a}^{(0)} = -\frac{2\alpha_s}{3\pi} \frac{1}{\bar{x}} \ln x \left[\ln \frac{Q^2}{\mu^2} - 1 + \frac{1}{2} \ln x \right] + \mathcal{O}(Q^{-2}). \quad (2.15)$$

The convolution of other one-loop parts of LCWF reads:

$$\begin{aligned}
 \int_0^1 \frac{dx}{x} \phi(x, \mu)|_{3c+4f} &= \frac{2\alpha_s}{3\pi} \frac{1}{x_0 \bar{x}_0} \left\{ -\ln^2 x_0 + 2 \ln \bar{x}_0 \ln x_0 + \ln x_0 \ln \frac{\mu^2}{m^2} + 2\text{Li}_2(x_0) \right. \\
 &\quad \left. - \frac{\pi^2}{3} + \bar{x}_0 \ln \frac{\mu^2}{m^2} + 2\bar{x}_0 \right\}, \\
 \int_0^1 \frac{dx}{x} \phi(x, \mu)|_{3b+4c} &= \frac{2\alpha_s}{3\pi x_0} \left[\ln \frac{\mu^2}{m^2} + 2 \right]. \quad (2.16)
 \end{aligned}$$

We note that the result in the first line can be used to subtract collinear singularities in figure 2c and that in the second line can be used for figure 2b. With these results one can extract the contributions of H from figure 2c and figure 2b:

$$\begin{aligned}
 H^{(1)}(x, Q, \mu)|_{2c} &= \frac{\alpha_s}{3\pi x} \left\{ \frac{1}{\bar{x}} \left[\ln^2 x - 2 \ln x \ln \frac{\mu^2}{Q^2} - (2+x) \ln x \right] - \ln \frac{\mu^2}{Q^2} - 4 \right\}, \\
 H^{(1)}(x, Q, \mu)|_{2b} &= \frac{\alpha_s}{3\pi x} \left\{ -\ln \frac{\mu^2}{Q^2} + \ln x - 4 \right\}.
 \end{aligned}
 \tag{2.17}$$

Finally the one-loop part of H can be given:

$$H(x, Q, \mu) = \frac{1}{x} + \frac{\alpha_s}{3\pi x} \left[\ln^2 x - \frac{x}{\bar{x}} \ln x - 9 + \ln \frac{Q^2}{\mu^2} (3 + 2 \ln x) \right] + (x \rightarrow \bar{x}) + \mathcal{O}(\alpha_s^2) \tag{2.18}$$

From eq. (2.16) we can see that the LCWF gives also a contribution with $\ln^2 x$ to H . The origin of this double log is that we use the light-cone gauge link. With the light-cone gauge link the contribution from figure 3c and figure 4f has a light-cone singularity beside a collinear singularity. The light-cone singularity is canceled in the sum. If we use gauge links with non light-cone vectors, the light-cone singularity will be regularized by the deviation of the vectors from the light-cone vector n .

The obtained H behaves like $xH \sim 1 + \alpha_s \ln^2 x / (3\pi)$ when x goes to zero. A resummation with a simple exponentiation does not work because of the $+$ -sign in the front of the $\ln^2 x$ term. Inspecting the one-loop part H one may chose μ as $\mu^2 = \sqrt{x}Q^2$ to kill the $\ln^2 x$ term. However, for small enough x the scale becomes so small that perturbative QCD can not be used. It seems that one needs extra nonperturbative objects beside the LCWF to complete the resummation. We will show in our work that the resummation can be done without those extra nonperturbative objects.

Before ending the section we would like to discuss the case if the dimensional regularization is used to regularize collinear singularities. In this case, the origin of $\ln^2 x$ is different than that with a quark mass. However the hard part is the same and it is expected that quantities which are free from collinear singularities will not depend how the collinear singularities are regularized.

3. Nonstandard light cone wave function

As discussed before, one can use non-light cone gauge links to define nonstandard light cone wave functions. A possible definition is a straightforward generalization of eq. (6):

$$\phi_+(x, \zeta, \mu) \sim \int \frac{dz^-}{2\pi} e^{ik^+z^-} \langle 0 | \bar{q}(0) L_u^\dagger(\infty, 0) \gamma^+ \gamma_5 L_u(\infty, z^- n) q(z^- n) | \pi^0(P) \rangle, \tag{3.1}$$

where the gauge link is

$$L_u(\infty, z) = P \exp \left(-ig_s \int_0^\infty d\lambda u \cdot G(\lambda u + z) \right), \quad u^\mu = (u^+, u^-, 0, 0). \tag{3.2}$$

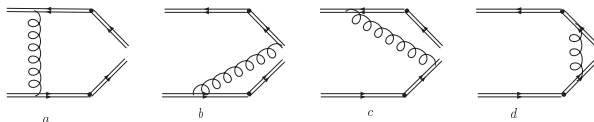

Figure 5: The one-loop contribution to products S of gauge links.

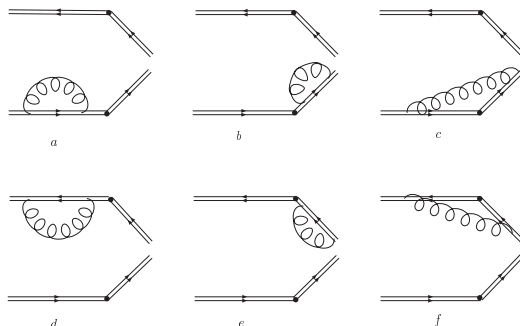

Figure 6: The one-loop contribution to products S of gauge links.

This definition is gauge invariant. The defined NLCWF depends on an extra parameter

$$\zeta^2 = \frac{2u^-(P^+)^2}{u^+} \approx \frac{4(u \cdot P)^2}{u^2}. \tag{3.3}$$

We will take the limit $u^- \gg u^+$ or $\zeta \rightarrow \infty$. The limit $\zeta \rightarrow \infty$ should be understood as that we do not take the contributions proportional to any positive power of u^+/u^- into account. It has no light-cone singularities as we will show through our one-loop result.

At tree-level the NLCWF is the same as the LCWF. At one-loop level, there are contributions given by all diagrams given in figure 3 and figure 4. However, the contributions from interactions between gauge links will cause some problems, especially the contribution from figure 3d. It should be noted that the contributions from interactions between gauge links, i.e., those from figure 3d, figure 4b and figure 3e, have no corresponding contributions in the form factor. A direct calculation shows that the contribution from figure 3d is not zero when $x = 0$ or $x = 1$. When this contribution convoluted with the tree-level hard part $H^{(0)}$ it will lead to divergences. Therefore these contributions need to be subtracted and a modification of the above definition is needed. Since only interactions between gauge links are involved in these contributions, one can consider to use products of gauge links to subtract them.

We consider the following products of gauge links:

$$\begin{aligned} S(z^-, u, v) &= \frac{1}{N_c} \text{Tr} \langle 0 | L_v^\dagger(0, -\infty) L_u^\dagger(\infty, 0) L_u(\infty, z^- n) L_v(z^- n, -\infty) | 0 \rangle, \\ S(z^-, u, n) &= \frac{1}{N_c} \text{Tr} \langle 0 | L_n^\dagger(0, -\infty) L_u^\dagger(\infty, 0) L_u(\infty, z^- n) L_n(z^- n, -\infty) | 0 \rangle, \\ S(z^-, n, v) &= \frac{1}{N_c} \text{Tr} \langle 0 | L_v^\dagger(0, -\infty) L_n^\dagger(\infty, 0) L_n(\infty, z^- n) L_v(z^- n, -\infty) | 0 \rangle. \end{aligned} \tag{3.4}$$

The vector v is taken as $v^\mu = (v^+, v^-, 0, 0)$ with $v^+ \gg v^-$. The fourier transformed S is:

$$S(q^+, u, v) = \int \frac{dz^-}{2\pi} e^{iq^+z^-} S(z^-, u, v). \quad (3.5)$$

At tree-level all S 's are 1 in the z^- -space or $\delta(q^+)$ in the q^+ -space. At one-loop level, they receive corrections from figure 5 and figure 6. It is interesting to note that there are certain relations between contributions of the three gauge link products. E.g., the contribution from figure 5b to $S(q^+, u, v)$ is:

$$S(q^+, u, v)|_{5b} = i\frac{4}{3}g_s^2 \int \frac{d^4k}{(2\pi)^4} \delta(k^+ + q^+) \frac{u \cdot v}{v \cdot k - i0} \cdot \frac{1}{u \cdot k - i0} \cdot \frac{1}{k^2 - \lambda^2 + i0}. \quad (3.6)$$

It is interesting to note that under the limit $v^+ \gg v^-$ and $u^- \gg u^+$:

$$\frac{u \cdot v}{(v \cdot k - i0)(u \cdot k - i0)} \approx \frac{1}{n \cdot k} \left[\frac{n \cdot v}{v \cdot k - i0} - \frac{n \cdot u}{u \cdot k - i0} \right], \quad (3.7)$$

where the first term corresponds to the contribution from figure 5b to $S(q^+, n, v)$, and the second term corresponds to that to $S(q^+, u, n)$, Hence we have:

$$S(q^+, u, v)|_{5b} = S(q^+, n, v)|_{5b} - S(q^+, u, n)|_{5b}. \quad (3.8)$$

The same result also holds for figure 5c and figure 6e and figure 6f. With this observation we define the soft factor:

$$\begin{aligned} \tilde{S}(z^-, \zeta_u) &= \frac{1}{2} [1 + S(z^-, u, v) - S(z^-, n, v) + S(z^-, u, n)], \\ \tilde{S}(q^+, \zeta_u) &= P^+ \int \frac{dz^-}{2\pi} e^{iq^+z^-} \tilde{S}(z^-, \zeta_u). \end{aligned} \quad (3.9)$$

With above results we have up to one-loop level:

$$\begin{aligned} \tilde{S}((x - x_0)P^+, \zeta_u) &= 1 + \frac{2\alpha_s}{3\pi} \left\{ \left(\frac{1}{x - x_0} \right)_+ [\theta(x_0 - x) - \theta(x - x_0)] \right. \\ &\quad \left. - \frac{1}{2} \delta(x - x_0) \left[\ln \frac{\zeta_u^2 (1 - x_0)^2}{\mu^2} + \ln \frac{\zeta_u^2 x_0^2}{\mu^2} \right] \right\} + \mathcal{O}(\alpha_s^2). \end{aligned} \quad (3.10)$$

The soft factor \tilde{S} only receives contributions from figure 5d and from the self-interaction of a gauge link, i.e., from figure 6a, figure 6b, figure 6d and figure 6e. These contributions are the same of those from figure 3d, figure 4b and figure 4c to the NLCWF, respectively. Therefore we can use this fact to subtract the contributions to ϕ_+ from figure 3d, figure 4b and figure 4e. It should be noted that the soft factor used here may be not unique. This non-uniqueness may be fixed through a study of higher orders and will not affect our one-loop results in this work. Also in the soft factor \tilde{S} one can take the limit $v \rightarrow l$ so that \tilde{S} does not depend on v .

We modify the definition of the NLCWF as:

$$\tilde{\phi}_+(x, \zeta, \mu) = \int \frac{dz^-}{2\pi} e^{ik^+z^-} \frac{\langle 0 | \bar{q}(0) L_u^\dagger(\infty, 0) \gamma^+ \gamma_5 L_u(\infty, z^- n) q(z^- n) | \pi^0(P) \rangle}{\tilde{S}(z^-, \zeta_u)}. \quad (3.11)$$

Its individual one-loop contributions are

$$\begin{aligned}
 \tilde{\phi}_+(x, \zeta)|_{3b} + \phi_+(x, \zeta)|_{4c} &= \frac{2\alpha_s}{3\pi} \phi_0 \left\{ \theta(x_0 - x) \left(-\frac{x}{x_0} \cdot \frac{1}{x - x_0} \right)_+ \ln \frac{\zeta^2 x_0^2}{m_q^2} \right. \\
 &\quad \left. + \delta(x - x_0) \left[\frac{1}{2} \ln \frac{\mu^2}{\zeta^2 x_0^2} - \frac{\pi^2}{6} + 1 \right] \right\} \phi_0, \\
 \tilde{\phi}_+(x, \zeta)|_{3c} + \phi_+(x, \zeta)|_{4f} &= \frac{2\alpha_s}{3\pi} \phi_0 \left\{ \theta(x - x_0) \left(\frac{\bar{x}}{\bar{x}_0} \cdot \frac{1}{x - x_0} \right)_+ \ln \frac{\zeta^2 \bar{x}_0^2}{m_q^2} \right. \\
 &\quad \left. + \delta(x - x_0) \left[\frac{1}{2} \ln \frac{\mu^2}{\zeta^2 \bar{x}_0^2} - \frac{\pi^2}{6} + 1 \right] \right\} \phi_0,
 \end{aligned} \tag{3.12}$$

it should be noted that there is no term like $(\ln(x - x_0)/(x - x_0))_+$ in comparison with $\phi_+(x, \mu)$, hence it will not lead to any term with $\ln^2 x$ when convoluted with $H^{(0)}$. The one loop result for $\tilde{\phi}$ reads:

$$\begin{aligned}
 \tilde{\phi}_+^{(1)}(x, \zeta, \mu) &= \frac{2\alpha_s}{3\pi} \left\{ \theta(x_0 - x) \left(-\frac{x}{x_0} \cdot \frac{1}{x - x_0} \right)_+ \ln \frac{\zeta^2 x_0^2}{m_q^2} \right. \\
 &\quad + \theta(x - x_0) \left(\frac{\bar{x}}{\bar{x}_0} \cdot \frac{1}{x - x_0} \right)_+ \ln \frac{\zeta^2 \bar{x}_0^2}{m_q^2} \\
 &\quad \left. + \delta(x - x_0) \left[\frac{1}{2} \ln \frac{\mu^2}{\zeta^2 x_0^2} + \frac{1}{2} \ln \frac{\mu^2}{\zeta^2 \bar{x}_0^2} - \frac{\pi^2}{3} + 2 \right] \right\} \phi_0 + \text{figure1a} \\
 &\quad + \frac{\alpha_s}{3\pi} \delta(x - x_0) \left[-\ln \frac{\mu^2}{m_q^2} + 2 \ln \frac{m_q^2}{\lambda^2} - 4 \right] \phi_0,
 \end{aligned} \tag{3.13}$$

the last line is from external-leg corrections.

There is an interesting relation between LCWF and NLCWF. It reads:

$$\tilde{\phi}_+(x, \zeta, \mu) = \int_0^1 dy C(x, y, \zeta, \mu) \phi(y, \mu), \tag{3.14}$$

where the function C can be calculated with perturbative QCD and does not contain any soft divergence. From our results we have:

$$\begin{aligned}
 C(x, y, \zeta, b, \mu) &= \delta(x - y) + \frac{2\alpha_s(\mu)}{3\pi} \left\{ \theta(x - y) \left[\frac{1}{x - y} \left(\frac{\bar{x}}{\bar{y}} \ln \frac{\zeta^2 (x - y)^2}{\mu^2} \right) \right]_+ \right. \\
 &\quad - \theta(y - x) \left[\frac{1}{x - y} \left(\frac{x}{y} \ln \frac{\zeta^2 (x - y)^2}{\mu^2} \right) \right]_+ \\
 &\quad \left. + \delta(x - y) \left[\frac{1}{2} \ln \frac{\mu^2}{\zeta^2 y^2} + \frac{1}{2} \ln \frac{\mu^2}{\zeta^2 \bar{y}^2} - \frac{\pi^2}{3} + 2 \right] \right\} + \mathcal{O}(\alpha_s^2).
 \end{aligned} \tag{3.15}$$

With the function we define another function which will be useful later:

$$\frac{\hat{C}(x, \zeta, \mu)}{x} = \int_0^1 \frac{dy}{y} C(y, x, \zeta, \mu). \tag{3.16}$$

which is just the convolution of C with the tree-level hard part from figure 1a. Again the function has a perturbative expansion:

$$\hat{C}(x, \zeta, \mu) = 1 - \frac{2\alpha_s(\mu)}{3\pi} \left\{ \frac{1}{\bar{x}} \left[-\ln^2 x + \ln x \ln \frac{\mu^2}{\zeta^2} + 2\text{Li}_2(x) - \frac{\pi^2}{3} \right] + \frac{1}{2} \ln \frac{\mu^2}{\zeta^2 x^2} + \frac{1}{2} \ln \frac{\mu^2}{\zeta^2 \bar{x}^2} + \frac{\pi^2}{3} + 2 \right\} + \mathcal{O}(\alpha_s^2), \quad (3.17)$$

4. The jet factor and re-factorization

After having studied the double log in LCWF, we need now to study how to factorize the double log $\ln^2 x_0$ from the form factor from figure 2c. As discussed before, the double log comes from the loop-momentum region where all components of the momentum carried by the gluon are at order of $x_0 Q$. One can use the eikonal approximation to expand the contribution in x_0 before the loop integration to obtain the dominant contribution. After some algebra we have:

$$\langle \gamma(p, \epsilon^*) | J_{e.m.}^\mu | k_q, k_{\bar{q}} \rangle_{2c} = \left[-i \frac{4g_s^2}{3} \int \frac{d^4 k}{(2\pi)^4} \frac{1}{k^2 + i0} \cdot \frac{1}{(k + k_q - p)^2 - m^2 + i0} \cdot \frac{p^-}{-2k^- + i0} \right] \cdot \langle \gamma(p, \epsilon^*) | J_{e.m.}^\mu | k_q, k_{\bar{q}} \rangle_{1a} + \mathcal{O}(x_0^0), \quad (4.1)$$

where we omitted irrelevant factors. The eikonal propagator $1/(-2k^- + i0)$ comes from the quark propagator from the anti-quark after emitting the gluon. This suggests that we can replace the anti-quark line with a suitable gauge link. However if we take the gauge link along the light-cone direction, it will produce a light-cone singularity in the integration over k^- as indicated above. To avoid this we can take the gauge link along non light-cone direction.

For our purpose we consider the following time-ordered product of gauge links with quark fields:

$$S_q(z) = \frac{1}{6i} \text{Tr} \left\{ \gamma^- \langle 0 | T \left[V_v^\dagger(0, -\infty) q(0) \bar{q}(z) V_{\tilde{u}}(z, -\infty) \right] | 0 \rangle \right\},$$

$$S_q(q) = \int d^4 z e^{-ix \cdot q} S_q(x), \quad (4.2)$$

with $q^\mu = (xP^+, -p^-, 0, 0)$. Without the gauge links, it is just a quark propagator. We first fix the vector v with $v^+ \gg v^-$ as discussed above. The gauge link with \tilde{u} is needed to make $S_q(q)$ gauge invariant. The direction of \tilde{u} will be give later. At tree-level we have

$$S_q(q) = \frac{1}{6i} \text{Tr} \left[\frac{i\gamma^- (\gamma \cdot q + m)}{q^2 - m^2} \right] = \frac{1}{q^+}. \quad (4.3)$$

At one-loop there are corrections from diagrams given in figure 7. The dominant contribution from figure 7c is proportional to the factor in $[\dots]$ in eq. (4.1) if the eikonal propagator $1/(-2k^- + i0)$ is replaced with $1/(-2v \cdot k + i0)$. Hence it will produce the same $\ln^2 x$ as that in the form factor from figure 2c. However, there are contributions involved

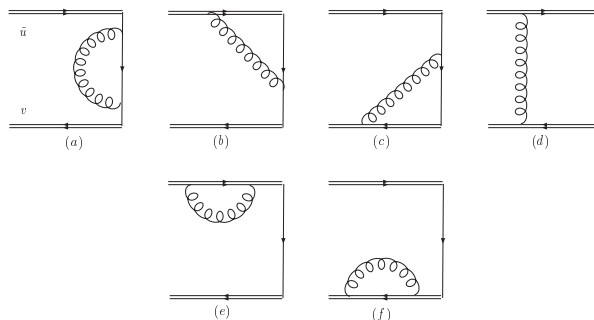

Figure 7: One-loop correction of S_q .

with interactions only between gauge links. They are those from figure 7d. Fig 7e and figure 7f. If we take the direction \tilde{u} as $\tilde{u}^\mu = (0, 0, \tilde{u}^1, \tilde{u}^2)$, the contribution from figure 7d can be eliminated because of $\tilde{u} \cdot v = 0$. The other two can be subtracted with expectation value of gauge links. We define the following jet factor as:

$$\hat{J}(x, \zeta_\gamma, Q, \mu) = \frac{q^+}{6i} \int d^4z e^{-iq \cdot z} \frac{\text{Tr} \left\{ \gamma^- \langle 0 | T \left[V_v^\dagger(0, -\infty) q(0) \bar{q}(z) V_{\tilde{u}}(z, -\infty) \right] | 0 \rangle \right\}}{\text{Tr} \langle 0 | T \left[V_v^\dagger(0, -\infty) V_{\tilde{u}}(0, -\infty) \right] | 0 \rangle},$$

$$q^\mu = (xP^+, -p^-, 0, 0), \quad Q^2 = 2P^+p^-, \quad \zeta_\gamma^2 = \frac{2v^+(p^-)^2}{v^-}, \quad (4.4)$$

with the denominator the contribution from figure 7e and figure 7f are subtracted. The tree-level contribution to \hat{J} is 1. The one-loop contributions are then from figure 7a, figure 7b and figure 7c. They are

$$\hat{J}(x, \zeta_\gamma, Q, \mu)|_{7a} = -\frac{\alpha_s}{3\pi} \left[\ln \left(\frac{\mu^2}{-q^2} \right) + 1 \right], \quad (4.5)$$

$$\hat{J}(x, \zeta_\gamma, Q, \mu)|_{7b} = \frac{\alpha_s}{3\pi q^+} \left[\ln \left(\frac{\mu^2}{-q^2} \right) + 2 \right],$$

$$\hat{J}(x, \zeta_\gamma, Q, \mu)|_{7c} = \frac{\alpha_s}{3\pi} \left[\ln \left(\frac{\mu^2}{-q^2} \right) + 2 + \ln \frac{\zeta_\gamma^2}{xQ^2} - \ln^2 \frac{\zeta_\gamma^2}{xQ^2} - \pi^2 - 4 \right] + \mathcal{O}(\hat{\zeta}_\gamma^{-1}).$$

At the order we consider \hat{J} does not depend on \tilde{u}^2 . We note that the $\ln^2 x$ term from figure 7c is exactly that from figure 2c contributing to the form factor as expected. With the above result one can derive the following evolution equations which will be useful for our resummation:

$$\frac{\partial}{\partial \ln \mu^2} \hat{J}(x, \zeta_\gamma, Q, \mu) = \frac{\alpha_s(\mu)}{3\pi} \hat{J}(x, \zeta_\gamma, Q, \mu),$$

$$\frac{\partial}{\partial \ln \zeta_\gamma^2} \hat{J}(x, \zeta_\gamma, Q, \mu) = \frac{\alpha_s(\mu)}{3\pi} \left(-2 \ln \frac{\zeta_\gamma^2}{xQ^2} + 1 \right) \hat{J}(x, \zeta_\gamma, Q, \mu). \quad (4.6)$$

With NLCWF and the jet factor we can write a factorized form for the form factor:

$$F(Q) \sim \int_0^1 dx \left[\frac{1}{x} \tilde{\phi}_+(x, \zeta, \mu) \hat{J}(x, \zeta_\gamma, Q, \mu) \tilde{H}(x, \zeta, \zeta_\gamma, Q, \mu) + (x \rightarrow 1-x) \right], \quad (4.7)$$

and $\tilde{H}(x)$ does not contain $\ln^2 x$ explicitly. The leading term \tilde{H} is one in the above. With our NLCWF we have the convolutions corresponding to that with LCWF in eq. (2.16), subtracted with the corresponding contributions from the form factor:

$$\begin{aligned}
 Q^2 F(Q^2)|_{2c} - \int_0^1 \frac{dx}{x} \tilde{\phi}(x, \zeta)|_{3c+4f} &= \frac{2\alpha_s}{3\pi x_0} \phi_0 \left[\frac{1}{\bar{x}_0} \left(-\frac{1}{2} \ln^2 x_0 + \ln x_0 \ln \frac{Q^2}{\zeta^2} \right. \right. \\
 &\quad \left. \left. + 2\text{Li}_2(x_0) - \frac{\pi^2}{3} \right) - \frac{1}{2} \ln \frac{\zeta^2 \bar{x}_0^2}{Q^2} - \frac{2+x_0}{2\bar{x}_0} \ln x_0 + \frac{\pi^2}{6} - 1 \right], \\
 Q^2 F(Q^2)|_{2b} - \int_0^1 \frac{dx}{x} \tilde{\phi}(x, \zeta)|_{3b+4c} &= \frac{2\alpha_s}{3\pi x_0} \left[\frac{1}{2} \ln \frac{Q^2}{\zeta^2 x_0} + \frac{\pi^2}{6} - 1 \right], \tag{4.8}
 \end{aligned}$$

it is clearly that all collinear singularities related to the quark mass are factorized into the NLCWF.

With the jet factor we have:

$$\begin{aligned}
 \tilde{H}(x, \zeta, \zeta_\gamma, Q, \mu) &= 1 + \frac{2\alpha_s(\mu)}{3\pi} \left\{ \frac{1}{\bar{x}} \left[\ln x \ln \frac{Q^2}{\zeta^2} + \frac{1}{2} \ln^2 \frac{Q^2}{\zeta_\gamma^2} + \ln x \ln \frac{Q^2}{\zeta_\gamma^2} \right] \right. \\
 &\quad \left. + \left[\ln \frac{Q^2}{\zeta^2} + \ln \frac{Q^2}{\mu^2} + \frac{1}{2} \ln \frac{Q^2}{\zeta_\gamma^2} \right] + \frac{1}{\bar{x}} \left(-\frac{x\pi^2}{3} + 2\text{Li}_2(x) \right) - 2 + \frac{\pi^2}{2} - \ln \bar{x} \right. \\
 &\quad \left. - \frac{3x}{2\bar{x}} \ln x - \frac{x}{2\bar{x}} \ln^2 \frac{xQ^2}{\zeta_\gamma^2} - \frac{x}{\bar{x}} \ln x \left(\ln \frac{Q^2}{\mu^2} - 1 + \frac{1}{2} \ln x \right) \right\} + \mathcal{O}(\alpha_s^2), \tag{4.9}
 \end{aligned}$$

as expected, for fixed ζ , ζ_γ and μ there are no terms like $\ln^2 x$. Also there are no terms like $\ln x$ without involving other log's.

5. Resummation

If we take $\tilde{\phi}_+$ as a nonperturbative object entirely, the resummation is really simple, in which we chose scales like μ , ζ and ζ_γ so that there is no large log's. E.g., we can take those scales and obtain \hat{H} which contains no large log's:

$$\begin{aligned}
 \mu^2 &= Q^2 = \zeta^2 = \zeta_\gamma^2, \\
 \hat{H}(x, Q, Q, Q, Q) &= 1 + \frac{2\alpha_s(\mu)}{3\pi} \left\{ \frac{1}{\bar{x}} \left(-\frac{x\pi^2}{3} + 2\text{Li}_2(x) \right) - 2 + \frac{\pi^2}{2} - \ln \bar{x} \right. \\
 &\quad \left. - \frac{3x}{2\bar{x}} \ln x - \frac{x}{2\bar{x}} \ln^2 x - \frac{x}{\bar{x}} \ln \bar{x} \left(-1 + \frac{1}{2} \ln \bar{x} \right) \right\} + \mathcal{O}(\alpha_s^2), \tag{5.1}
 \end{aligned}$$

and for the jet factor we use the evolution equation of ζ_γ to express \hat{J} at $\zeta_\gamma = Q$ with that at $\zeta_\gamma = \sqrt{x}Q$:

$$\begin{aligned}
 \hat{J}(x, Q, Q, Q) &= \exp \left\{ -\frac{\alpha_s(Q)}{3\pi} [\ln^2 x + \ln x] \right\} \hat{J}(x, \sqrt{x}Q, Q, Q), \\
 \hat{J}(x, \sqrt{x}Q, Q, Q) &= 1 + \frac{\alpha_s}{3\pi} [-\ln x - 1 - \pi^2], \tag{5.2}
 \end{aligned}$$

it should be noted that $\hat{J}(x, \sqrt{x}Q, Q, Q)$ has no $\ln^2 x$ term. Only the single log $\ln x$ remains. Then for the form factor we have:

$$F(Q) \sim \int_0^1 dx \left[\frac{1}{x} \tilde{\phi}_+(x, Q) \hat{J}(x, \sqrt{x}Q, Q, Q) \tilde{H}(x, Q, Q, Q, Q) \exp \left\{ -\frac{\alpha_s(Q)}{3\pi} [\ln^2 x + \ln x] \right\} + (x \rightarrow 1-x) \right]. \quad (5.3)$$

Taking $\tilde{H}\hat{J}$ as a perturbative function, it does not contain $\ln^2 x$. The terms with $\ln^2 x$ are resummed in the exponential, but one needs the information of $\tilde{\phi}$ to make predictions.

With our results one can indeed resum $\ln^2 x$ in the factorization formula with LCWF. One can use the relation between ϕ and $\tilde{\phi}$ to write another factorization formula for the form factor:

$$F(Q) \sim \int_0^1 dx \left[\frac{1}{x} \phi(x, \mu) \hat{C}(x, \zeta, \mu) \hat{J}(x, \zeta_\gamma, Q, \mu) \hat{H}(x, \zeta, \zeta_\gamma, Q, \mu) + (x \rightarrow 1-x) \right], \quad (5.4)$$

and take \hat{C} , \hat{J} and \hat{H} as perturbative functions. \tilde{H} is the same as \hat{H} at one-loop level. If we expand the product $\hat{C}\hat{J}\tilde{H}$, we return to the standard collinear factorization discussed in section 2. With the product its each part has a clear meaning. The ζ -dependence in \hat{C} will control the behavior of $x \rightarrow 0$ in LCWF, while the ζ_γ dependence in \hat{J} controls that in the form factor. The evolution equations of \hat{C} can be obtained from results in section 3. They are:

$$\begin{aligned} \frac{\partial}{\partial \ln \mu^2} \hat{C}(x, \zeta, \mu) &= -\frac{2\alpha_s(\mu)}{3\pi} \left(\frac{1}{x} \ln x + 1 \right) \hat{C}(x, \zeta, \mu), \\ \frac{\partial}{\partial \ln \zeta^2} \hat{C}(x, \zeta, \mu) &= \frac{2\alpha_s(\mu)}{3\pi} \left(\frac{1}{x} \ln x + 1 \right) \hat{C}(x, \zeta, \mu). \end{aligned} \quad (5.5)$$

For the resummation we first chose a scale μ_1 in the factorization formula and use the μ -evolution to express $\hat{C}(x, \zeta, \mu_1)$ with $\hat{C}(x, \zeta, \mu)$:

$$\hat{C}(x, \zeta, \mu_1) = \exp \left\{ -\frac{8}{3\beta_0} \ln \frac{\alpha_s(\mu)}{\alpha_s(\mu_1)} \left(\frac{\ln x}{x} + 1 \right) \right\} \hat{C}(x, \zeta, \mu), \quad (5.6)$$

where we have used the one-loop α_s -running:

$$\alpha_s(\mu) = \frac{4\pi}{\beta_0} \left(\ln \frac{\mu^2}{\Lambda^2} \right)^{-1}, \quad \beta_0 = 11 - \frac{2}{3}n_f. \quad (5.7)$$

We then use the ζ -evolution to express $\hat{C}(x, \zeta, \mu)$ with $\hat{C}(x, \zeta_0, \mu)$:

$$\hat{C}(x, \zeta, \mu) = \exp \left\{ \frac{2\alpha_s(\mu)}{3\pi} \left(\frac{\ln x}{x} + 1 \right) \ln \frac{\zeta^2}{\zeta_0^2} \right\} \hat{C}(x, \zeta_0, \mu), \quad (5.8)$$

now we take $\zeta_0^2 = \mu^2/x$, so that $\hat{C}(x, \zeta_0, \mu)$ does not have any log's:

$$\hat{C}(x, \mu/\sqrt{x}, \mu) = 1 - \frac{\alpha_s(\mu)}{3\pi} \left[\frac{1}{x} \left(2\text{Li}_2(x) - \frac{\pi^2}{3} \right) - \frac{1}{2} \ln \bar{x} + \frac{\pi^2}{3} + 2 \right] + \mathcal{O}(\alpha_s^2). \quad (5.9)$$

With these steps, all log terms in \hat{C} are resummed:

$$\hat{C}(x, \zeta, \mu_1) = \exp \left\{ - \left[\frac{8}{3\beta_0} \ln \frac{\alpha_s(\mu)}{\alpha_s(\mu_1)} - \frac{2\alpha_s(\mu)}{3\pi} \ln \frac{x\zeta^2}{\mu^2} \right] \left(\frac{\ln x}{\bar{x}} + 1 \right) \right\} \hat{C}(x, \mu/\sqrt{\bar{x}}, \mu). \quad (5.10)$$

Now we have the freedom to chose μ so that the exponential does not go to ∞ when x goes to 0. We can take μ fixed by:

$$\alpha_s(\mu) = x\alpha_s(\mu_1), \quad \ln \frac{\mu^2}{\Lambda^2} = \frac{1}{x} \ln \frac{\mu_1^2}{\Lambda^2}, \quad (5.11)$$

and

$$\hat{C}(x, \zeta, \mu_1) = \exp \left\{ - \frac{8}{3\beta_0} \left[\ln x - \frac{\beta_0}{4\pi} x\alpha_s(\mu_1) \ln x - x \frac{\alpha_s(\mu_1)}{\alpha_s(\zeta)} + 1 \right] \left(\frac{\ln x}{\bar{x}} + 1 \right) \right\} \hat{C}(x, \mu/\sqrt{\bar{x}}, \mu). \quad (5.12)$$

For $x \rightarrow 0$ we have now:

$$\hat{C}(x, \zeta, \mu_1) \sim \exp \left\{ - \frac{8}{3\beta_0} \ln^2 x \right\}, \quad (5.13)$$

and it goes to zero fast than any positive power of x .

By taking the scales

$$\mu_1^2 = Q^2 = \zeta^2 = \zeta_\gamma^2, \quad (5.14)$$

and using the ζ_γ -evolution to express \hat{J} at $\zeta_\gamma^2 = Q^2$ with \hat{J} at $\zeta_\gamma^2 = xQ^2$, we obtain our resummed form for the form factor:

$$F(Q) \sim \int_0^1 dx \left[\frac{1}{x} \phi(x, Q) \hat{J}(x, \sqrt{x}Q, Q, Q) \hat{H}(x, Q, Q, Q, Q) \hat{C}(x, \mu/\sqrt{\bar{x}}, \mu) \exp \{-S(x, Q)\} \right. \\ \left. + (x \rightarrow 1-x) \right], \\ S(x, Q) = \frac{8}{3\beta_0} \left[\ln x - \frac{\beta_0}{4\pi} x\alpha_s(Q) \ln x - x + 1 \right] \left(\frac{\ln x}{\bar{x}} + 1 \right) + \frac{\alpha_s(Q)}{3\pi} [\ln^2 x + \ln x], \\ \approx \left(\frac{8}{3\beta_0} + \frac{\alpha_s(Q)}{3\pi} \right) \ln^2 x, \text{ for } x \rightarrow 0, \quad (5.15)$$

in the above the product $\hat{C}\hat{H}\hat{J}$ does not contain any log's, except \hat{J} has a single log $\ln x$. All other logs, like $\ln^2 x$, etc., are resummed in S . Since we only used one-loop evolutions, for consistence we should neglect higher orders in α_s in the product. Therefore, we have the one-loop resummed form factor:

$$F(Q) = \frac{1}{3\sqrt{2}Q^2} \int_0^1 dx \left[\frac{1}{x} \phi(x, Q) \exp \{-S(x, Q)\} + (x \rightarrow 1-x) \right], \\ = \frac{\sqrt{2}}{3Q^2} \int_0^1 dx \frac{1}{x} \phi(x, Q) \exp \{-S(x, Q)\}. \quad (5.16)$$

This form can be used if one can get $\phi(x, Q)$ easily at the large scale Q . If one only knows the wave function at lower scale, but does not want to solve the evolution equation for the

wave function to get it at a higher scale, one can first evolve everything at a lower scale μ_0 where the wave function is known or modeled, then to a higher scale μ_1 and perform the resummation. We get in this case:

$$F(Q) = \frac{\sqrt{2}}{3Q^2} \int_0^1 dx \frac{1}{x} \phi(x, \mu_0) \exp \left\{ -S(x, Q) - \frac{8}{3\beta_0} \ln \frac{\alpha_s(Q)}{\alpha_s(\mu_0)} \left(\ln x + \frac{3}{2} \right) \right\}, \quad (5.17)$$

where we have used:

$$\frac{\partial (\hat{C}\hat{H}\hat{J})}{\partial \ln \mu^2} = -\frac{2\alpha_s(\mu)}{3\pi} \left(\ln x + \frac{3}{2} \right) (\hat{C}\hat{H}\hat{J}). \quad (5.18)$$

6. Numerical results and comparison with experiment

We will use our resummation formula in eq. (5.17) and eq. (5.18) to give our numerical results. In our formulas the nonperturbative input is the LCWF. The LCWF has the asymptotic form if μ goes to ∞ :

$$\phi(x, \mu) = 6x(1-x)f_\pi + \dots, \quad (6.1)$$

where \dots stand for terms which are zero in the limit $\mu \rightarrow \infty$. The LCWF can be expanded with Gegenbauer polynomials [1]. A model for ϕ has been proposed by truncating the expansion [18]:

$$\phi(x, \mu) = 6f_\pi x(1-x) \left(1 + \phi_2(\mu) C_2^{3/2}(2x-1) \right), \quad (6.2)$$

where $\phi_2(\mu_0)$ is determined by QCD sum-rule method at $\mu_0 = 1\text{GeV}$ [18]:

$$\phi_2(\mu_0 = 1\text{GeV}) = 0.44. \quad (6.3)$$

We will use these two types of LCWF to give our numerical results. We will use eq. (5.16) with the asymptotic form of ϕ to make our numerical predictions. For LCWF given in eq. (6.2) we use eq. (5.17). We take the Λ -parameter as $\Lambda = 237\text{MeV}$. Our numerical results do not strongly depend on the value of Λ . There is only a little change if we change Λ from 100MeV to 300MeV .

Our numerical results are given in figure 8, where experimental results from CLEO in [10] are also given. From figure 8 we see that with the two types of LCWF the resummation has significant effects. The resummation can reduce the form factor predicted without the resummation at the level of 40% or more. Using the LCWF given in eq. (6.2) with our resummation the experimental results can be well described for $Q^2 \geq 3\text{GeV}^2$.

7. Conclusion

In the collinear factorization the form factor of the transition $\gamma^*\pi^0 \rightarrow \gamma$ can be written as a convolution of a hard part and LCWF. The hard part contains double log terms as $\ln^2 x$ at one-loop level and is expected to have terms $\ln^{2n} x$ at order of α_s^n . A resummation of these terms with a simple exponentiation can not be done because it results in divergent

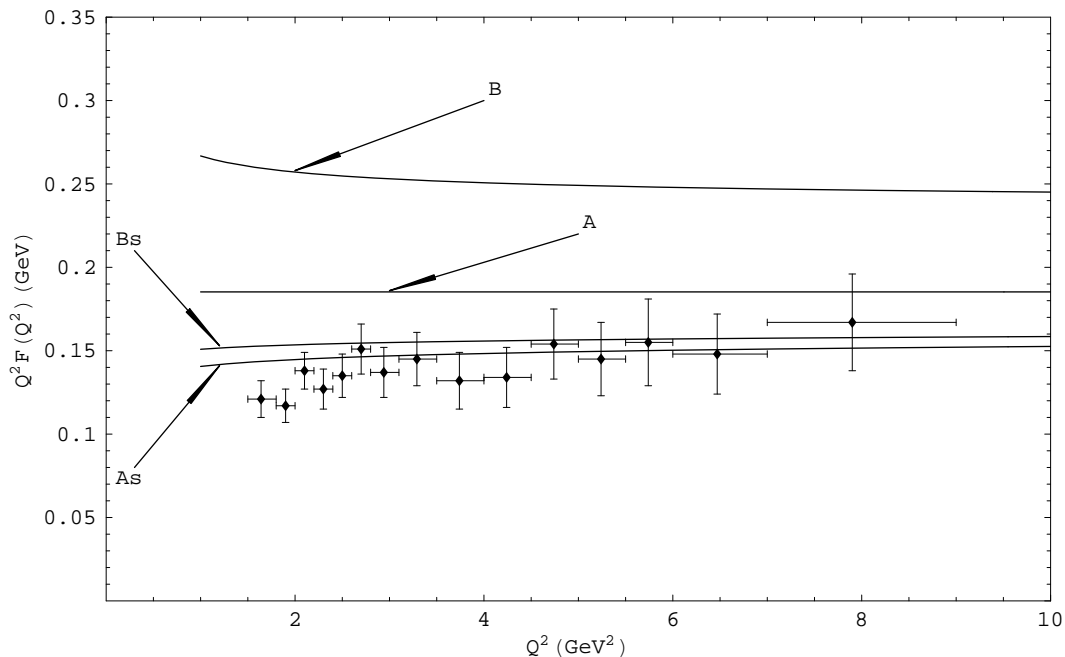

Figure 8: Numerical results with experimental data. The curve A and curve As are obtained by using the asymptotic form without and with the resummation, respectively. The curve B and curve Bs are obtained by using the LCWF in eq. (6.2) without and with the resummation, respectively. The experimental data are taken from the second reference in [10].

results. In this work we have studied the resummation of these $\ln^2 x$ terms. With a small but finite quark mass as the regulator of collinear singularities, we have found that the $\ln^2 x$ terms come partly from the light-cone wave function and partly from the form factor, as discussed in section 2. To handel these terms, we first introduce a nonstandard light-cone wave function with the gauge links off the light-cone direction. This introduces an extra scale in the NLCWF beside the renormalization scale μ . The deviation from the light-cone direction will regularize light-cone singularities in each contributions. This fact leads to that the NLCWF will not deliver any term with $\ln^2 x$ to the hard part, if one uses the NLCWF to perform the factorization. As the next, we introduce a jet factor to factorize the $\ln^2 x$ term in the form factor. The jet factor also contains an extra scale beside μ . This extra scale controls the x -behavior of the jet factor. Our re-factorized formula for the form factor is a convolution with the NLCWF, the jet factor and a hard part. The hard part does not contain terms with $\ln^2 x$.

We have found that there is an interesting relation between the LCWF and the introduced NLCWF. The relation can be determined with perturbative QCD and is given at one-loop level in this work. With this relation we are able to show that the $\ln^2 x$ can be resummed and the nonperturbative object in the resummed formula is only the LCWF. With the knowledge of LCWF's we are able to get numerical predictions. In performing the resummation of the double log we have used the concept of QCD factorization and

worked out every quantity explicitly at one-loop level. It is possible to extend our work to the resummation of the remaining single log terms and beyond one-loop level.

Our numerical results show that the effect of the resummation is significant. There is a difference at the level of 40% or more between the predicted form factors with and without the resummation. In comparison with experiment we find that the numerical predictions by using the LCWF in eq. (6.2) with the resummation are consistent with the experimental data.

Acknowledgments

This work is supported by National Nature Science Foundation of P.R. China (No. 10575126, No. 10421003).

References

- [1] G.P. Lepage and S.J. Brodsky, *Exclusive processes in perturbative quantum chromodynamics*, *Phys. Rev. D* **22** (1980) 2157.
- [2] V.L. Chernyak and A.R. Zhitnitsky, *Asymptotic behavior of exclusive processes in QCD*, *Phys. Rept.* **112** (1984) 173.
- [3] S. Narison, *Muon and tau anomalies updated*, *Phys. Lett. B* **513** (2001) 53 [[hep-ph/0103199](#)]; A.P. Bakulev, S.V. Mikhailov and N.G. Stefanis, *Unbiased analysis of cleo data at NLO and pion distribution amplitude*, *Phys. Rev. D* **67** (2003) 074012 [[hep-ph/0212250](#)]; *CLEO and E791 data: a smoking gun for the pion distribution amplitude?*, *Phys. Lett. B* **578** (2004) 91 [[hep-ph/0303039](#)].
- [4] A. Schmedding and O.I. Yakovlev, *Perturbative effects in the form factor $\gamma\gamma^* \rightarrow \pi_0$ and extraction of the pion wave function from CLEO data*, *Phys. Rev. D* **62** (2000) 116002 [[hep-ph/9905392](#)].
- [5] P. Kroll and M. Raulfs, *The $\pi\gamma$ transition form factor and the pion wave function*, *Phys. Lett. B* **387** (1996) 848 [[hep-ph/9605264](#)]; R. Jakob, P. Kroll and M. Raulfs, *Meson-photon transition form-factors*, *J. Phys. G* **22** (1996) 45 [[hep-ph/9410304](#)].
- [6] F.-G. Cao, T. Huang and B.-Q. Ma, *The perturbative pion-photon transition form factors with transverse momentum corrections*, *Phys. Rev. D* **53** (1996) 6582 [[hep-ph/9603330](#)].
- [7] I.V. Musatov and A.V. Radyushkin, *Transverse momentum and Sudakov effects in exclusive QCD processes: $\gamma^*\gamma\pi_0$ form factor*, *Phys. Rev. D* **56** (1997) 2713 [[hep-ph/9702443](#)].
- [8] F. del Aguila and M.K. Chase, *Higher order QCD corrections to exclusive two photon processes*, *Nucl. Phys. B* **193** (1981) 517; E. Braaten, *QCD corrections to meson - photon transition form-factors*, *Phys. Rev. D* **28** (1983) 524; E.P. Kadantseva, S.V. Mikhailov and A.V. Radyushkin, *Total α_s corrections to processes $\gamma^*\gamma^* \rightarrow \pi_0$ and $\gamma^*\pi \rightarrow \pi$ in a perturbative QCD*, *Yad. Fiz.* **44** (1986) 507.
- [9] B. Melic, D. Mueller and K. Passek-Kumericki, *Next-to-next-to-leading prediction for the photon-to-pion transition form factor*, *Phys. Rev. D* **68** (2003) 014013 [[hep-ph/0212346](#)]; *BLM scale setting for the pion transition form factor*, *Phys. Rev. D* **65** (2002) 053020 [[hep-ph/0107295](#)].

- [10] CLEO collaboration, J. Gronberg et al., *Measurements of the meson photon transition form factors of light pseudoscalar mesons at large momentum transfer*, *Phys. Rev. D* **57** (1998) 33 [[hep-ex/9707031](#)].
- [11] G. Sterman, *Summation of large corrections to short distance hadronic cross-sections*, *Nucl. Phys. B* **281** (1987) 310.
- [12] J. Botts and G. Sterman, *Hard elastic scattering in QCD: leading behavior*, *Nucl. Phys. B* **325** (1989) 62.
- [13] H.-n. Li and G. Sterman, *The perturbative pion form-factor with Sudakov suppression*, *Nucl. Phys. B* **381** (1992) 129.
- [14] J.P. Ma and Q. Wang, *Transverse-momentum dependent factorization for $\gamma^* \pi_0 \rightarrow \gamma$* , *Phys. Rev. D* **75** (2007) 014014 [[hep-ph/0607234](#)]; *On transverse-momentum dependent light-cone wave functions of light mesons*, *Phys. Lett. B* **642** (2006) 232 [[hep-ph/0605075](#)].
- [15] J.P. Ma and Q. Wang, *Transverse momentum dependent factorization for radiative leptonic decay of B-meson*, *JHEP* **01** (2006) 067 [[hep-ph/0510336](#)]; *Transverse momentum dependent light-cone wave function of B-meson and relation to the momentum integrated one*, *Phys. Lett. B* **613** (2005) 39 [[hep-ph/0412282](#)].
- [16] J.C. Collins and F. Hautmann, *Infrared divergences and non-lightlike eikonal lines in sudakov processes*, *Phys. Lett. B* **472** (2000) 129 [[hep-ph/9908467](#)].
- [17] H.-n. Li, *Threshold resummation for B meson decays*, *Phys. Rev. D* **66** (2002) 094010 [[hep-ph/0102013](#)].
- [18] V.M. Braun and I.E. Filyanov, *QCD sum rules in exclusive kinematics and pion wave function*, *Z. Physik C* **44** (1989) 157; *Conformal invariance and pion wave functions of nonleading twist*, *Sov. J. Nucl. Phys.* **52** (1990) 126.